



Fiberstars
Lighted Laminar Flow Fountains

SAVE THESE DIRECTIONS!

These directions are provided to ensure the proper installation and operation of Fiberstars Lighted Laminar Flow Fountain. The maximum lighted distance of the laminar stream should be considered approximately 8ft height and 8ft in distance. If the laminar arc is over 8ft there is a high degree of probability that the lighting will not travel the full distance to the bottom of the laminar flow. Also, if the throw distance is over 8ft, the lighting will also fail to go the full distance of the laminar stream.

IMPORTANT GENERAL SPECIFICATIONS:

1. The water supply to the laminar fountains should be filtered with a cartridge filter. Sand filter and DE filters will likely produce small particles of debris that will clog the filter screens internal to the laminar flow fountains.
2. Water supply is dependent upon 3 important factors:
 - a. Pump size – if dedicated pump is used it must be a minimum of a ½ hp and supply proper flow rate at 16 ft of head.
 - b. Plumbing pipe size
 - c. Number of laminar flow fountains on system

**NOTE: GENERAL RULE OF THUMB IS THAT EACH LAMINAR REQUIRES
A MINIMUM OF 10 GPM.
SEE FOLLOWING SECTION ON DESIGN CRITERIA**

**THE LAMINAR FLOW DECK BOX IS MADE OF ABS MATERIAL. USE
ONLY ABS-PVC GLUE WHEN MAKING ANY PLUMBING CONNECTIONS
TO THIS DECK BOX**

3. Each Fiberstars Lighted Laminar flow fountain contains 150 strands of fiber. **Minimum sized conduit is 1”**. Always use sweep 90’s to allow the fiber to be pulled easily through the conduit.
4. Fiberstars Lighted Laminar Flow Fountains can be place in most any location from concrete decks, raised bond beams or even soft scapes. Be sure that the distance from the interior pool wall to the laminar flow fountain is no further than 5 feet. This would allow the lighted laminar flow stream to be approximately 3 feet into the pool interior.

5. Each fountain requires a 1 ½” PVC water supply that is reduced to ¾” to connect to the bottom of the deck box.
6. On main water supply line install a check valve and system bypass valve. Adjust bypass valve until desired flow is achieved to Laminar Fountain.

INSTALLATION OF THE LAMINAR FLOW DECK BOX

1. Reconfirm that fountain is no further than 5 feet away from water surface interior.
2. Prepare location by digging hole 2 feet in diameter and depth.
 - A. For in deck applications – Level the lid to the finished grade level of decking.
 - B. For planter areas – Laminar lid should be 2 inches ABOVE the landscape area to prevent materials from intruding or washing into the fountain itself.
3. Remove the laminar flow fountain from the deck box assembly by undoing the S.S. clamp on the ½” flex hose at the bottom of the fountain.
4. Insert included plug into ½” flex pipe. Secure with S.S. clamp for pressure testing.
5. Place the deck box into the excavated hole with the internal water connection pointing in the direction of the desired water flow (towards pool interior).
6. The bottom of the deck box can be supported by utilizing the two 1” PVC support connection. The support pipe should be approximately 6” in length. You may also wire tie the deck box to any decking rebar using the 4 rebar support wings to help maintain the proper level.
7. Attach the ¾” PVC supply line to the inlet fitting.
8. Install ¾” PVC pipe for fiberoptic cable run. It is highly suggested that you install all fiber conduits with sweep fittings for easy of installation.
9. Install 1” PVC pipe for drainage. **IT IS IMPERATIVE THAT ALL LAMINAR FLOW FOUNTAINS HAVE PROPER DRAINAGE.**



10. Fill excavated area with gravel until gravel reaches approximately 1” up on bottom of deck box.

11. Finish your deck material installation making sure that the Lighted Laminar Flow fountains remain level. Utilizing the Adjustable Deck Flange adjust to match your deck height.

After deck box has been installed and system has been pressure tested, the laminar flow fountain itself may be reinstalled.

IT IS EXTREMELY IMPORTANT THAT THE WATER SUPPLY TO EACH LAMINAR IS ALLOWED TO BE FLUSHED SO THAT ALL MATERIAL THAT MIGHT BE IN THE LINES ARE BLOWN FREE PRIOR TO BE REINSTALLED INTO THE LAMINAR FLOW ITSELF.

ADJUSTING WATER FLOW

The water flow is determined by two factors: GPM water flow and angle of laminar.

Set angle of your laminar flow by using the two adjustment knobs on the inside the deck box on either side of the laminar. Adjust your distance by opening or closing each respective gate valve until the desired distance is achieved. **MAXIMUM HEIGHT AND DISTANCE IS APPROXIMATELY 8 FEET.**

Initial start up should be done gradually, allowing each laminar to fill with water slowly and allowing air to escape. Failure to do so may cause damage to unit and plumbing. **DO NOT EXCEED 20 GPM PER LAMINAR OR DAMAGE CAN BE DONE INTERNALLY.**

IMPORTANT NOTES AND REMINDERS

Always leave 2 feet of fiber on the inside of each laminar flow deck box for servicing.

Max fiber runs are 5 feet off fiber distance. This is caused by plumbing fitting, etc.

20 feet = 15 feet maximum distance

40 feet = 35 feet maximum distance

Fill conduit connection inside of the deck box with silicone or similar material to prevent water from entering fiber area.



Minimize the number of plumbing fittings in the water run to cut down flow restrictions and water turbulence.

When using multiple laminar flow fountains it is extremely important that the fiberoptic cables are the same length, regardless if they are different distances from the illuminator.

Example: If you have 1 laminar at 20ft and another at 40ft, both should have 40ft of fiber.

Laminar flow fountains are susceptible to wind conditions and the higher the angle of your fountain the more they may be effected. If your area has regular amounts of high winds you may consider moving the laminars closer to the pool edge and decreasing the angle of the fountain.

For adjustment of Fiberstars Light Enhancement Device (Scratcher) please see attached direction sheet.

FOR WINTERIZATION, THE LAMINAR FLOW FOUNTAIN CAN BE REMOVED BY DISCONNECTING THE FIBER AT THE BOTTOM BY LOOSNING THE CONNECTION AND BY UNSCREWING THE 2 QUICK DISCONNECTS FOR WATE SUPPLY.

If internal screens of the Lighted Laminar Flow become obstructed this will effect the laminar stream. To correct this, please remove laminar fountain from the deck box assembly and apply water pressure at the laminar fountain exit point. This will back flush the laminar and allow debris to be exited from the bottom.

After back flushing of the reinstall the laminar fountain and adjust water flow and angle for desired effect.

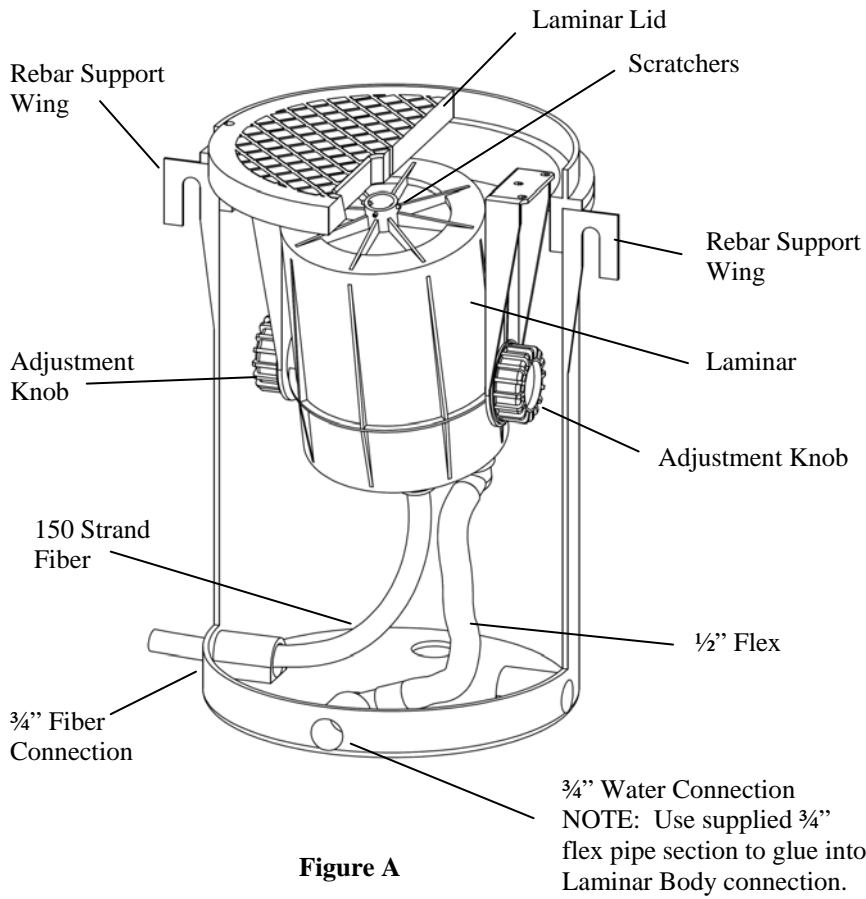

Figure A

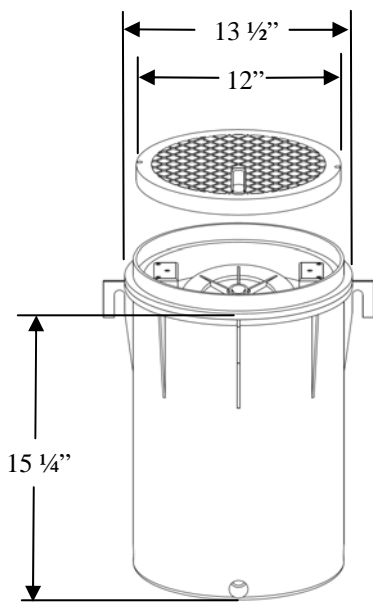

Figure B

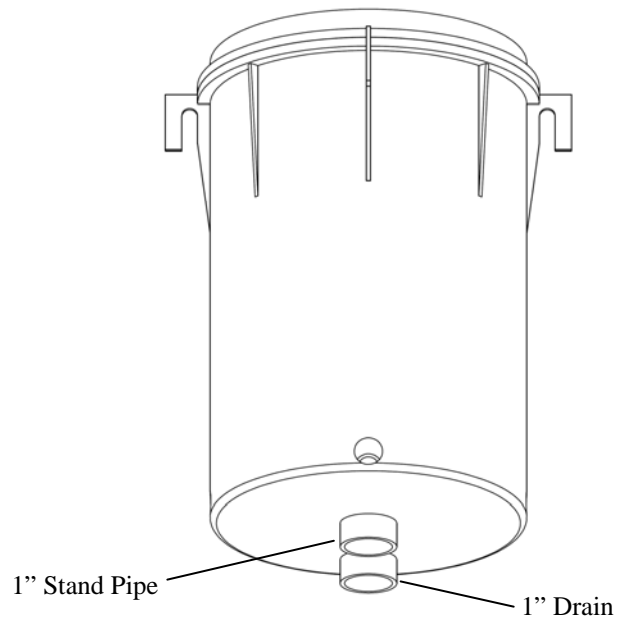

Figure C

Lighted Laminar Light Enhancement Device

In order to achieve maximum light output, the Light Enhancement Device will need to be adjusted. Adjustment of the “scratcher” or Light Enhancement Device will increase the light output of the laminar flow stream and also will allow you to create water effects such as “pulsing” of the flow stream and light output.

NOTE: For best effects the following should be done in a dark or nighttime environment

Adjustment

1. Ensure that all connections and other installation requirements have been completed.
2. Turn on and operate system as per other directions. This will allow you to adjust the water direction and height properly along with the water flow (GPM) that you wish to achieve.
3. Once both of the above have been completed, turn off system.
4. Raise the laminar flow lid/fountain by the edge of the deck box approximately 4 inches.
5. Insert 1 – 2” x 4” board under each side of the lid, parallel with the slot in the lid, so that the lid is supported, yet raised up from the deck box base.
6. Turn back on the system and reestablish water flow to the fountain.
7. The “scratcher” has 3 adjustment screws. Adjust each screw so that the tip just touches the water flow. (See diagram below)

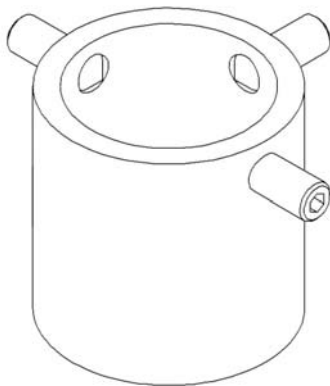

8. As you increase the contact area of each screw you can achieve different light effects, such as pulsing or burping of the light and water flow.
9. Once you have made the adjustments to achieve your desired effects, add a little drop of silicon or a non permanent thread locking compound on each screw. Turn off the system and remove the 2” x 4” braces and set the laminar/lid back into place on the deck box flange.
10. Turn on the system one last time as a final inspection to insure that the lighting effect you adjusted for in #7 is still there. You may have to do several adjustments to achieve the maximum lighting effect.

of Large laminars

	1	2	3	4
GPM	10	20	30	40
Head (FT)	18	21	31	42

Pipe Size

# of units	A	B	C
1	1.5"	1"	3/4"
2	1.5"	1.5"	3/4"
3	2"	1.5"	3/4"
4	2"	1.5"	3/4"

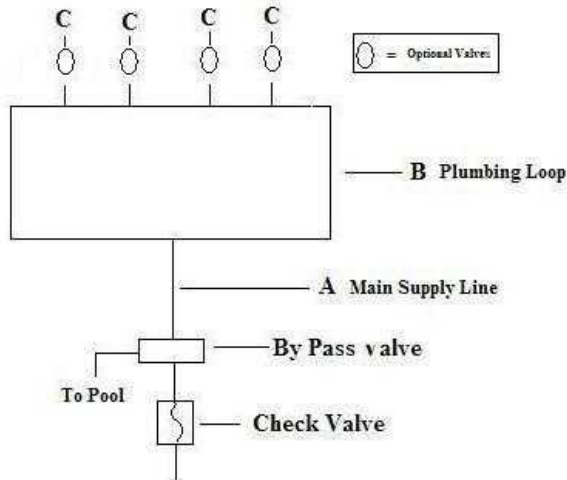

Fiberstars Large Lighted Laminar Fountains Flow and Plumbing Chart